



Dual-Domain Structural Interference Detection in FDMA based Satellite Communication Networks using Carrier-Aware Spectral Cursor (CASC)

Sahal Mohammed M.N, Abhiram N, Bhimeswara Rao M, Rath D N & Shivani K L
ISRO Telemetry Tracking and Command Network (ISTRAC), Bangalore, India

Presented by:

सहल मोहम्मद एम एन/ Sahal Mohammed M N

वैज्ञानिक/ अभियंता-एसडी/ Scientist/Engineer-'SD'

इस्ट्रैक/ इसरो/ ISTRAC/ ISRO

अंतरिक्ष विभाग, भारत सरकार/ Department of Space, Government of India

बेंगलुरु, कर्नाटका, भारत/ Bangalore, Karnataka, India

Email:sahal@istrac.gov.in

INTRODUCTION

- ❑ ISTRAC operates a fleet of ground stations spread across and outside the India.
- ❑ Depending on the mission, various stations are used for Telemetry, Tracking & Command operations.
- ❑ SATCOM facilitates data transfer from the ground stations to the Control center through satellite communication links.

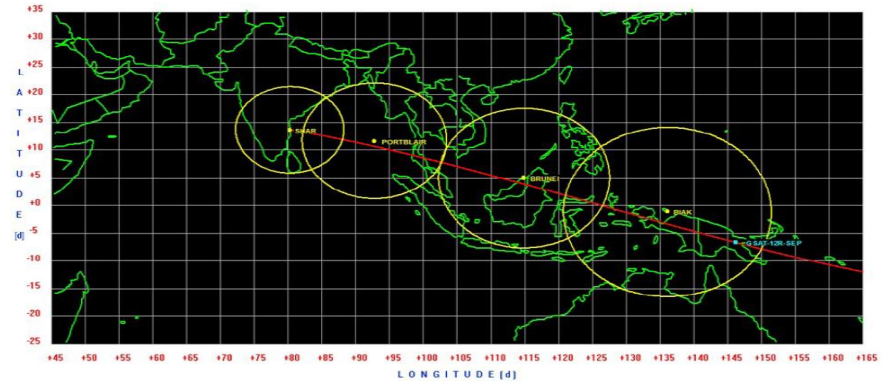
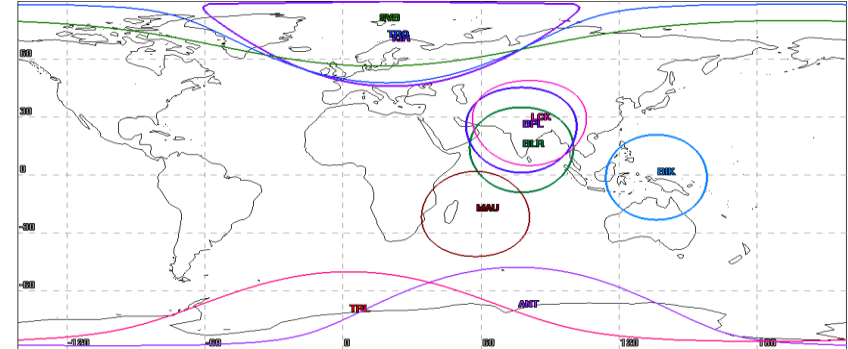

Satellite communication

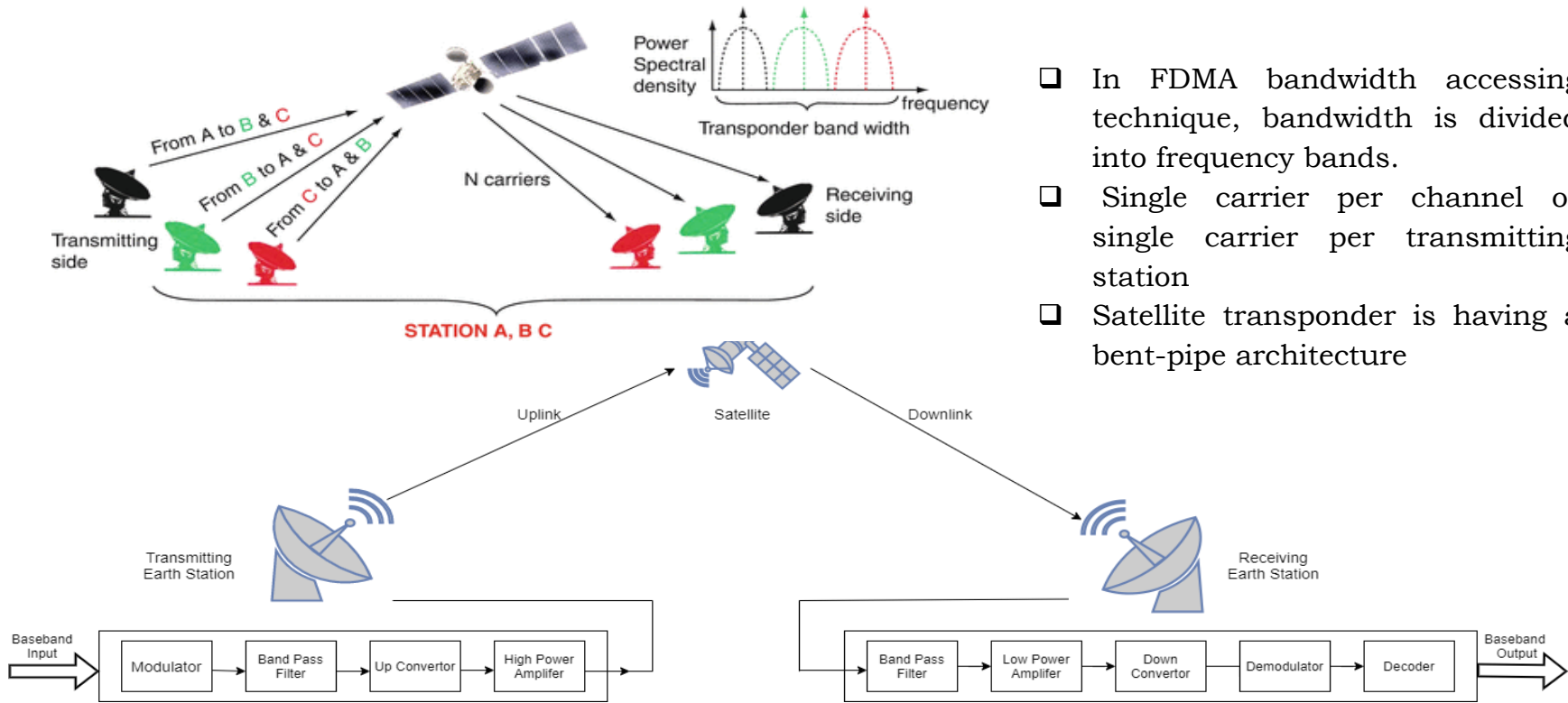

- ❑ In FDMA bandwidth accessing technique, bandwidth is divided into frequency bands.
- ❑ Single carrier per channel or single carrier per transmitting station
- ❑ Satellite transponder is having a bent-pipe architecture

Interferences in satellite communication

- ❑ Interferences pose a major concern in the satellite communication.
- ❑ Various interferences are possible such as cross-pol interference, adjacent channel interference, adjacent satellite interference, 5G interference etc.
- ❑ Inefficient systems can also be a cause for interference. Examples are high intermodulation, leakage of SSPA power, FM interference, LO leakage etc.

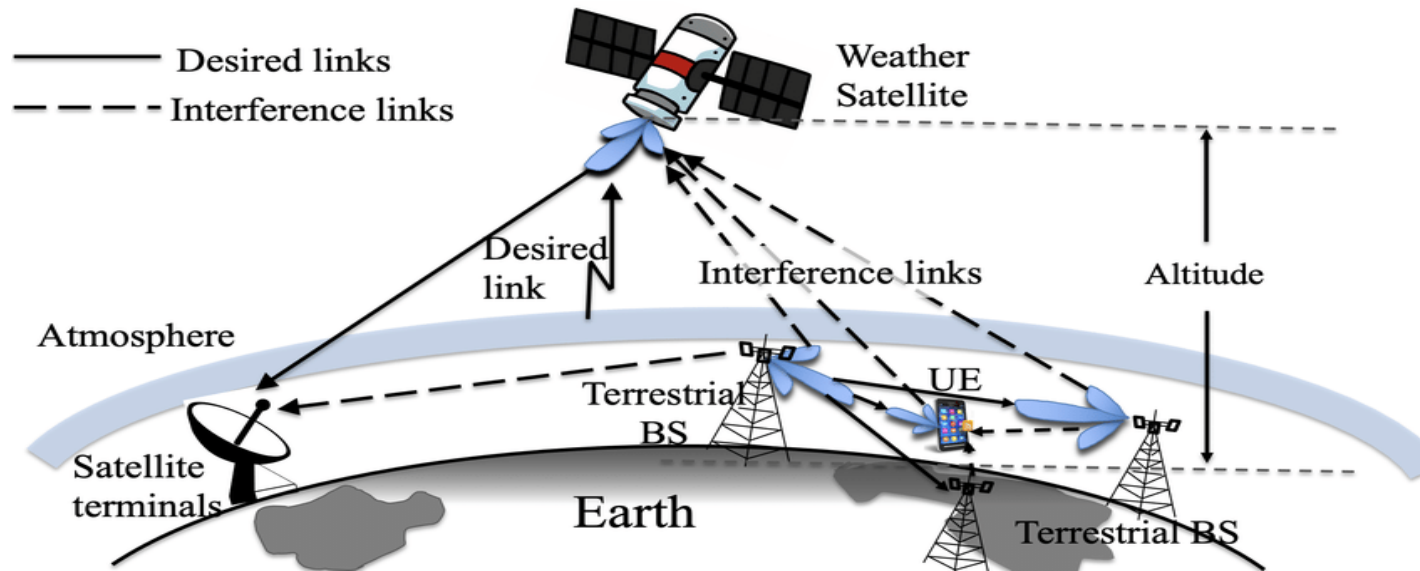

Cross-polar interference

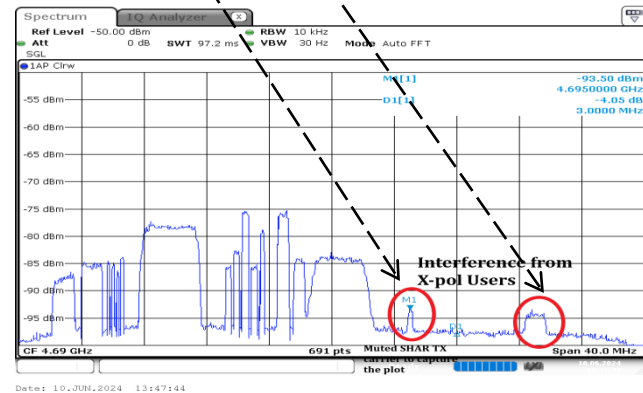
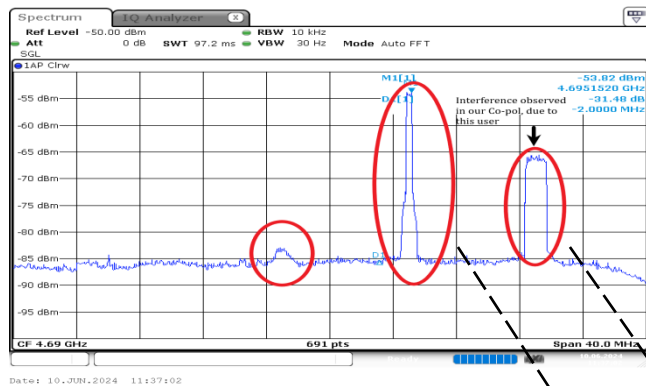
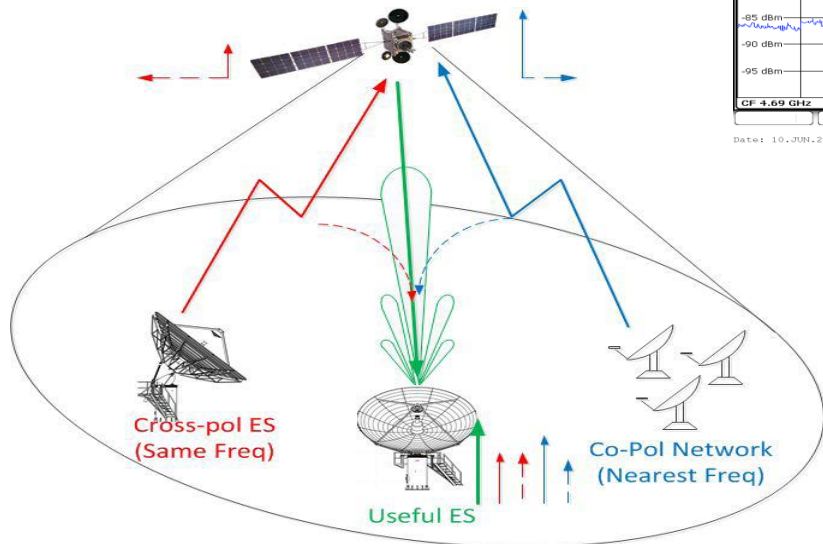

Cross-polar interference (contd..)

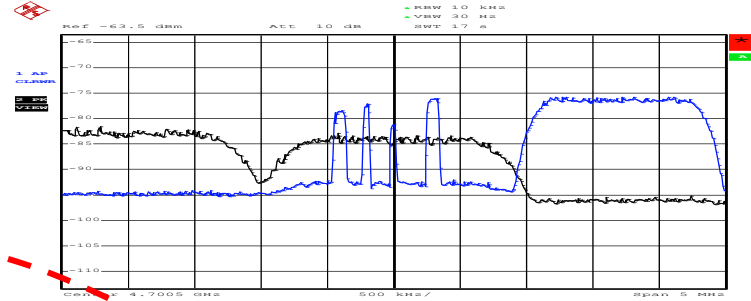
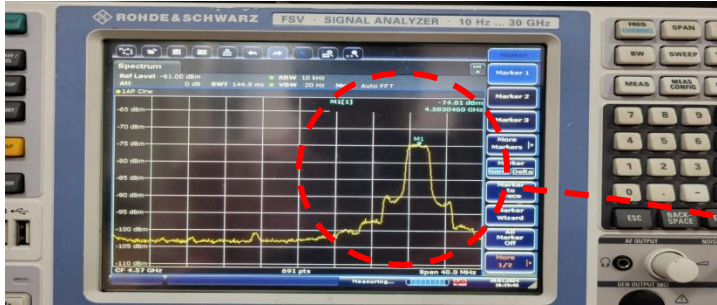

Date: 22 JUN 2017 12:51:20

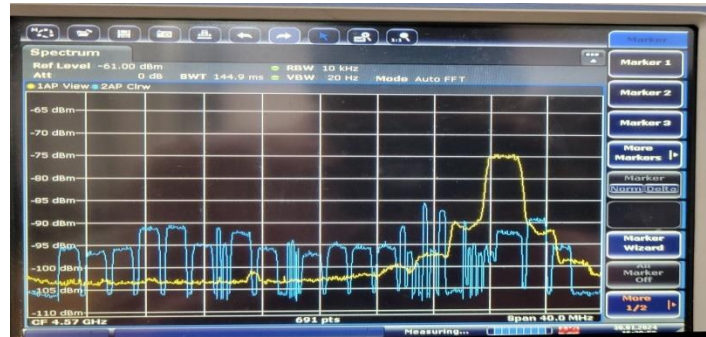

Adjacent satellite interference

- ❑ ASI can happen if the satellites are separated by $< 2^\circ$
- ❑ Two types of ASI: Downlink ASI and Uplink ASI

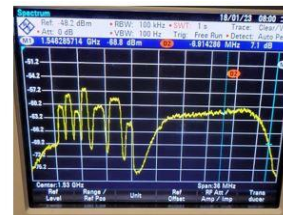
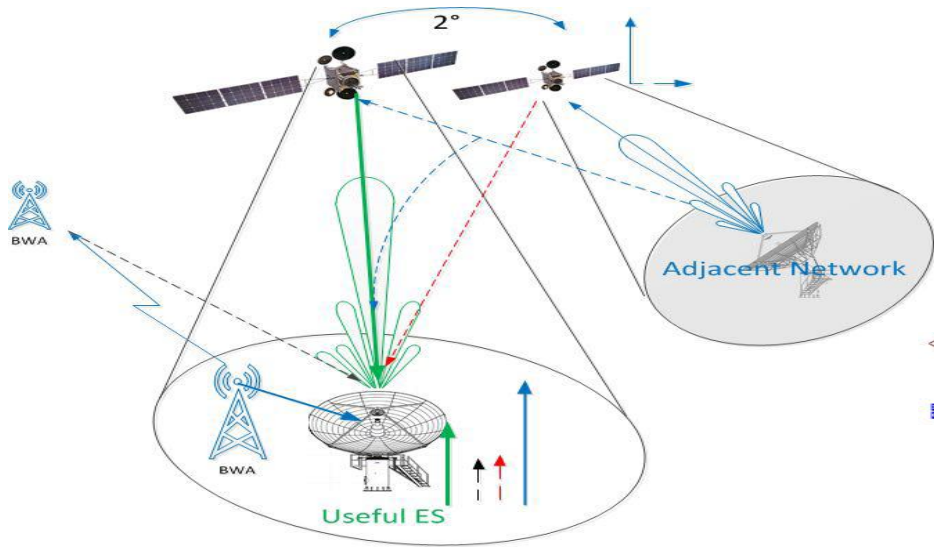

Spectrum during interference



After switching off all carriers



After shifting carriers from the interference frequency band

Interference

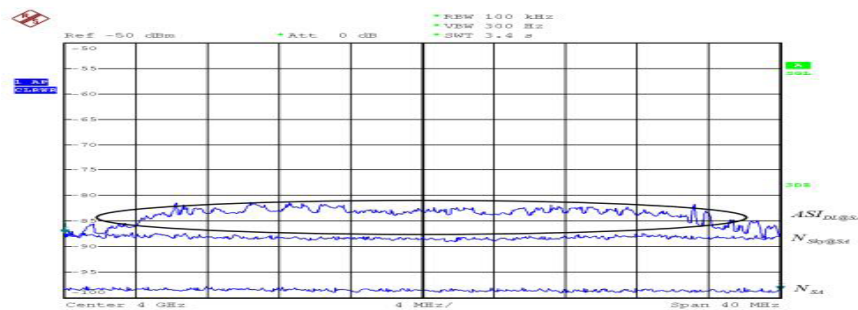

Other common interferences in SatCom

Sweeping carrier interference

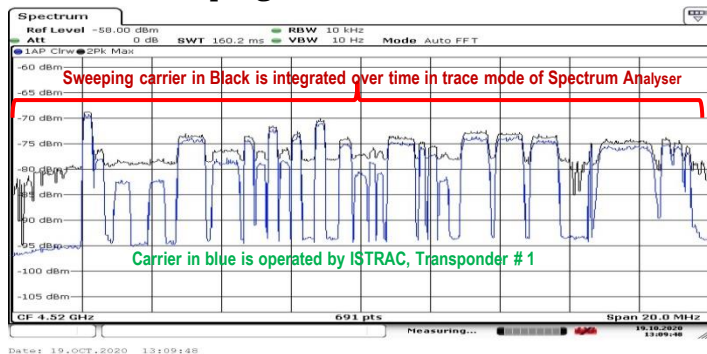

Interfering carrier wrongly operating in the allotted frequency band of the user

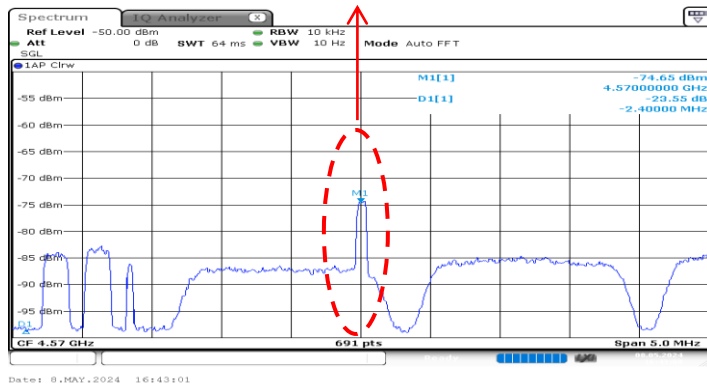

Interference due to leakage

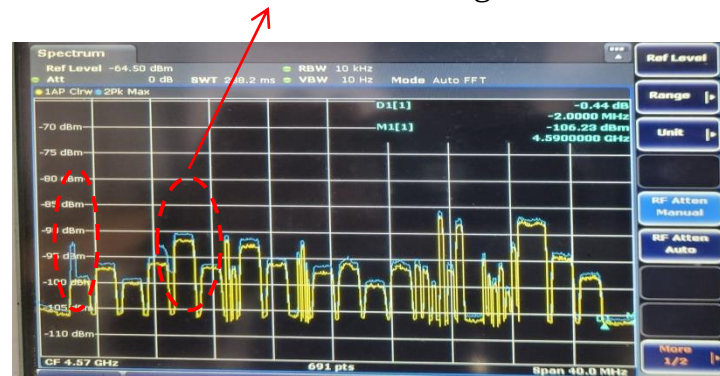

Anomalies in spectrum

- ❑ Interferences result in anomaly in the downlink spectrum monitored

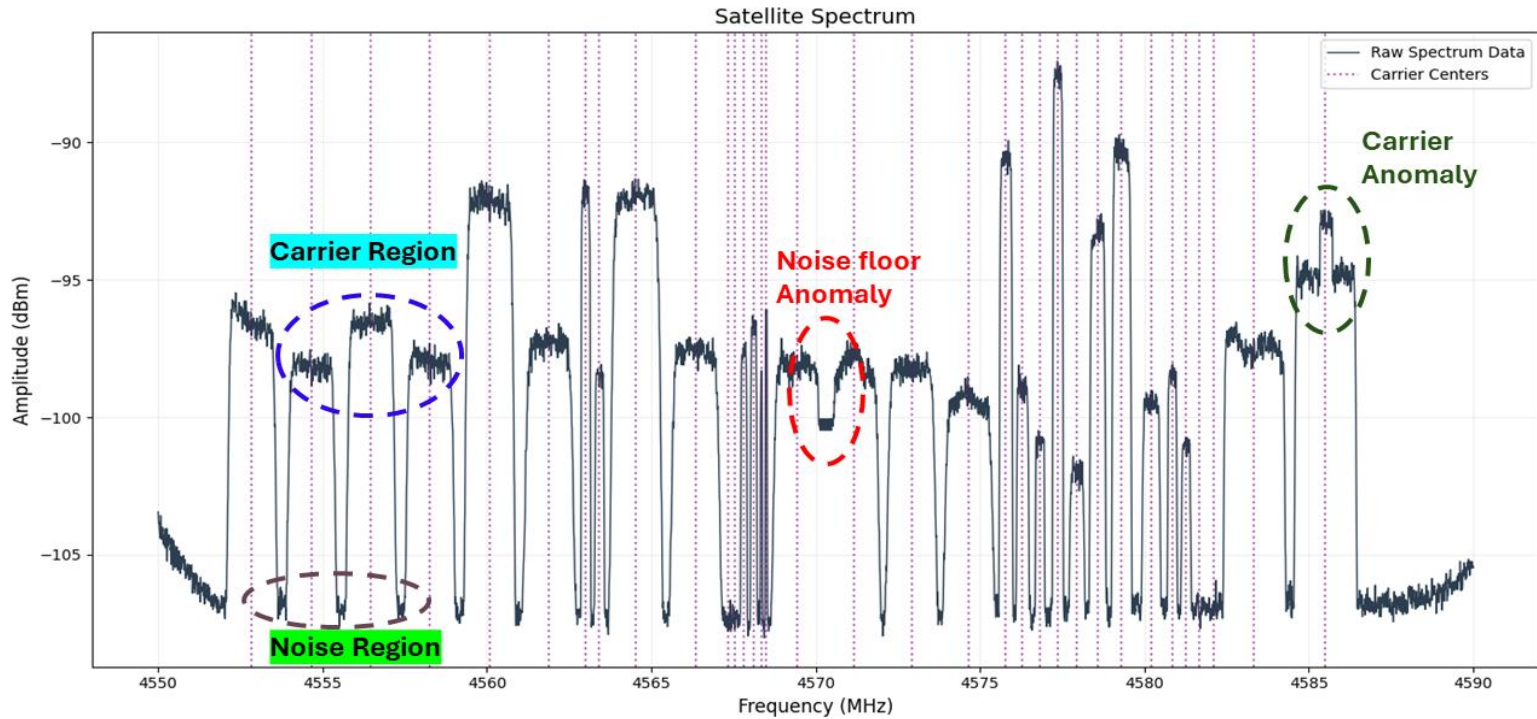

Proposed automatic interference detection technique

Centralized control

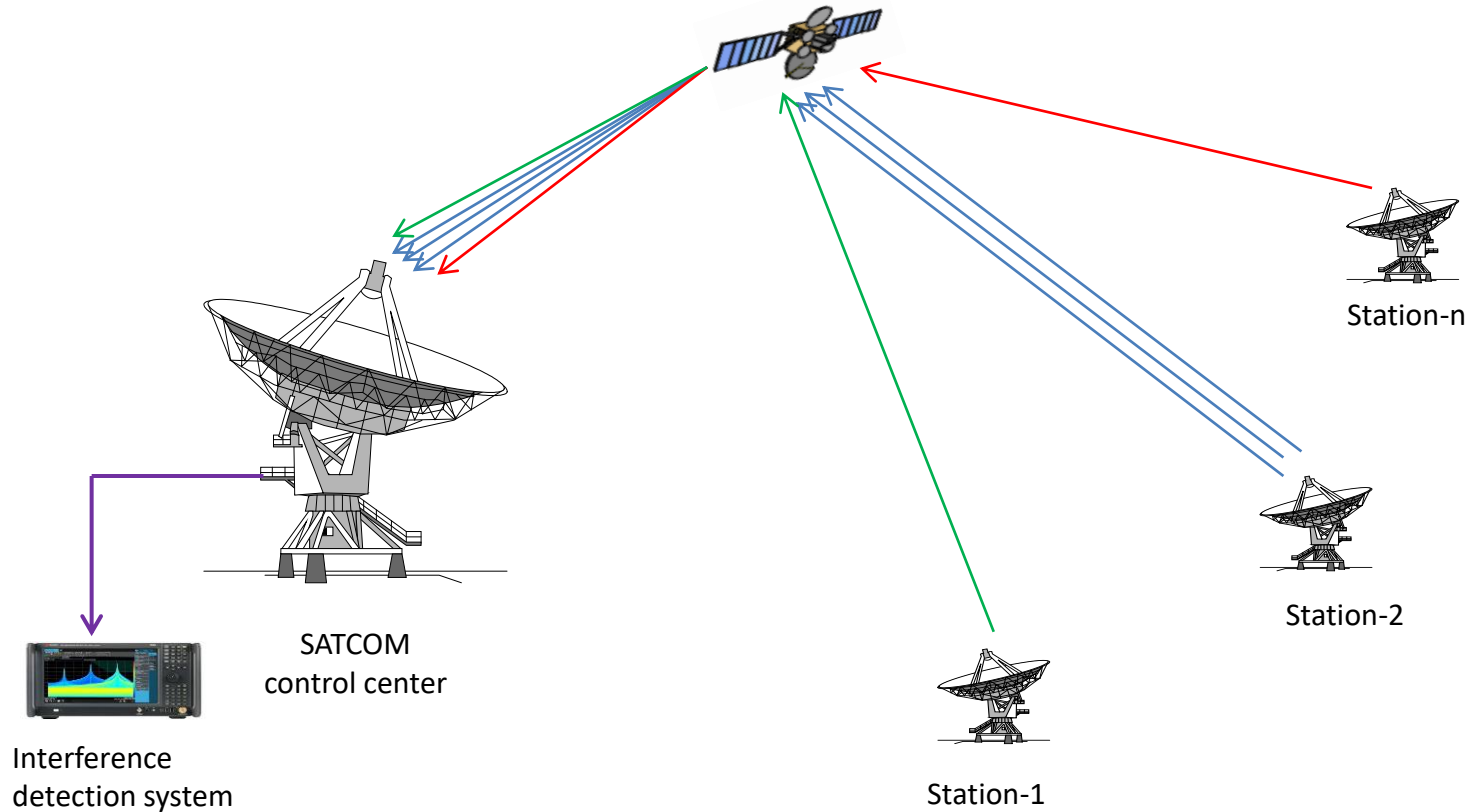

Methodology

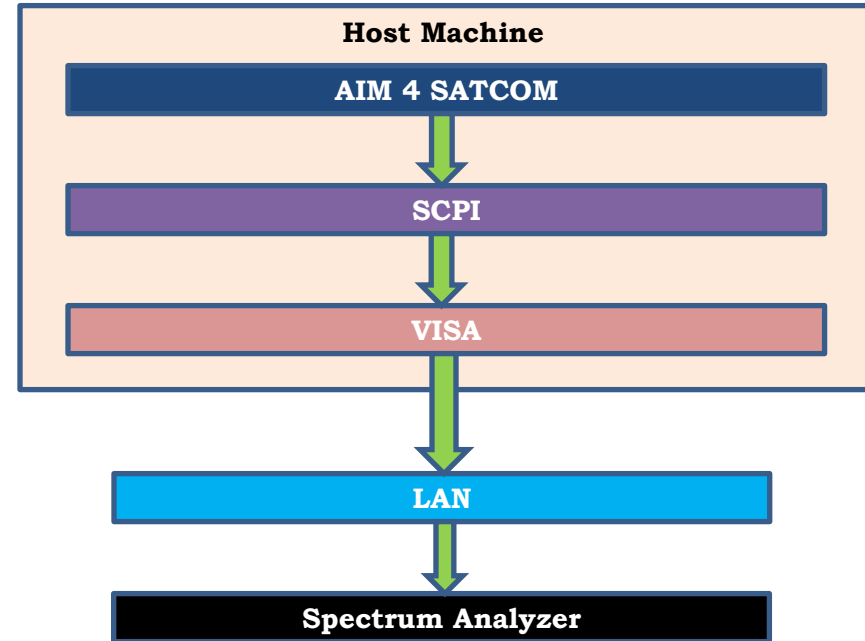
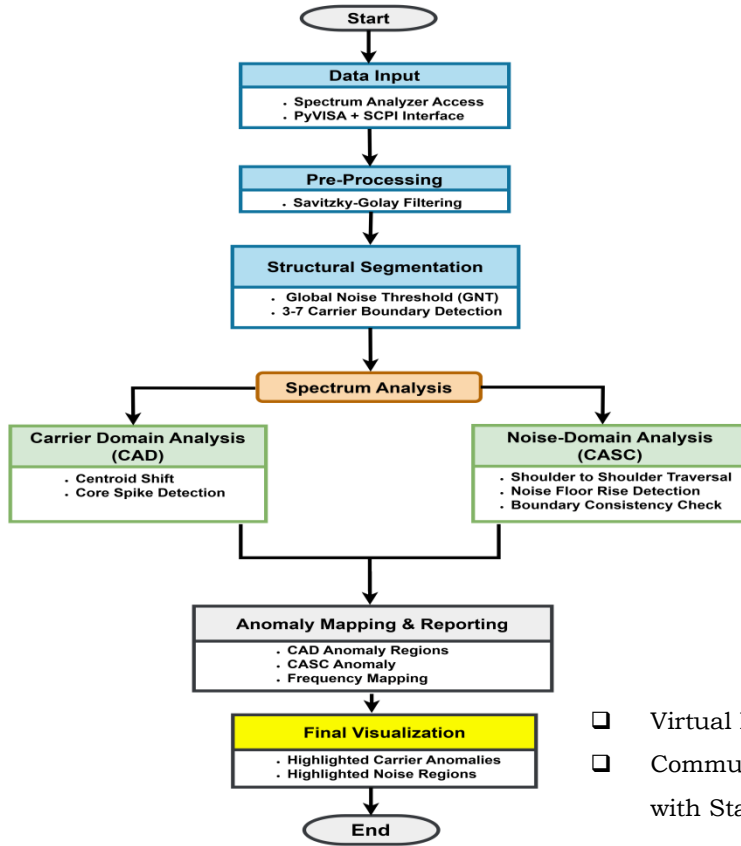

- ❑ Virtual Instrument Software Architecture (VISA) is used as the communication platform.
- ❑ Communication between the application and Spectrum Analyzer is through LAN based connection with Standard Commands for Programmable Instruments (SCPI) as the communication language.

Code Architecture

1. Raw Spectrum

via PyVISA / TCPIP
RBW, VBW, SPAN etc

2. GNT Estimation

Valley-median noise
floor
prominence = 2.5 dB

3. Edge Detection

3-7 Algorithm
ba_l sh_l ci sh_r
ba_r

4. CAD Detectors

Centroid · Hump · Spike
ShoulderExcess ·
TransitionStep

5. CASC Detection

Inter-carrier noise rise
gnt + 1.2 dB threshold

Round-Robin Architecture

Single VISA session shared across all three transponders sequentially. Spectrum analyzer sweeps all configured transponders in one cycle.

Round-robin means the single VISA session sweeps the transponders sequentially in a fixed order

Clean Spectrum

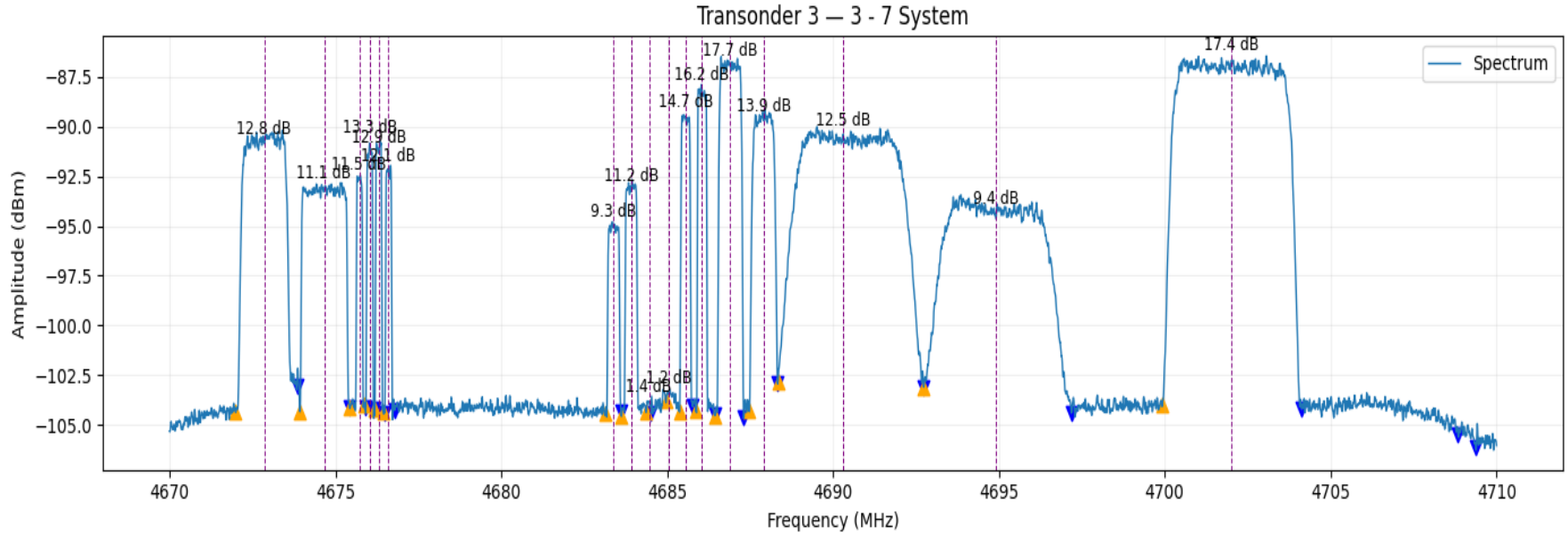

Visualization conventions

Edge Markers

▲ ba_l	Left base edge — orange triangle-up
▼ ba_r	Right base edge — blue triangle-down
◆ sh_l	Left shoulder — green diamond
◆ sh_r	Right shoulder — pink diamond
★ sh_l_corr	Corrected left shoulder — orange star
★ sh_r_corr	Corrected right shoulder — pink star
-- GNT	Global Noise threshold

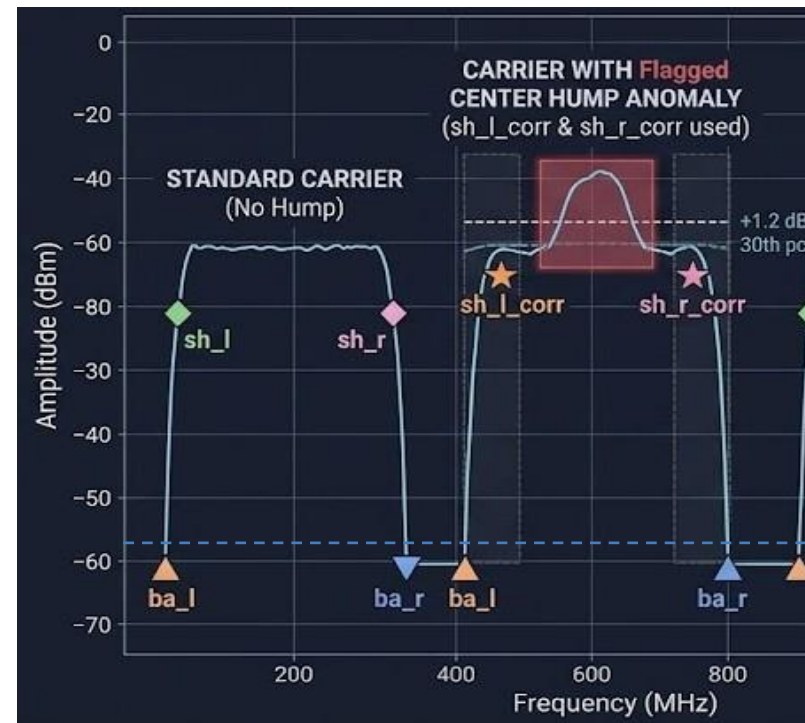

Edge detection using 3-7 algorithm

ci — Carrier Center

Looked up from frequency chart (MHz). Used as starting point for outward walk.

thr = y[ci] - 2.0 dB

Shoulder threshold. Walk finds sh_l/sh_r where amplitude first drops below this.

3-7 Condition (ba_l/ba_r)

$$y[i-3] \geq y[i] \text{ AND } y[i-7] \geq y[i]$$

Both look-aheads must confirm non-rising trend.

GNT Gate (use_gnt)

If local min is not close to GNT, walk forced to continue until $y[i] \leq \text{gnt} + 1.5 \text{ dB}$. Prevents premature stop on crowded transponders.

t_candidates

Points where 3-7 fired but GNT gate prevented stop. Stored for TransitionStep detection.

Output Markers

- ▲ ba_l Left base edge (orange triangle-up)
- ▼ ba_r Right base edge (blue triangle-down)
- ◆ sh_l Left shoulder (green diamond)
- ◆ sh_r Right shoulder (pink diamond)
- ★ sh_l_corr Corrected left shoulder (orange star)
- ★ sh_r_corr Corrected right shoulder (pink star)

Why 3 AND 7?

A single 3-point look-ahead catches noise bumps but can stop prematurely on a local trough. Requiring both 3 AND 7 points to confirm a non-rising trend ensures the walk has found a sustained descent toward the noise floor

Global Noise Threshold (GNT)

Method

Savgol-smooth raw spectrum (window=31, poly=3) → find valleys via `find_peaks(-sm, prominence=2.5)` → 50th percentile of ± 10 samples around each valley

Why valley-median?

Inter-carrier gaps represent the true noise floor. Simple global minimum is pulled down by deep nulls or instrument spikes. Valley sampling avoids carrier-occupied regions entirely.

Why prominence=2.5?

Ensures only genuine inter-carrier valleys are used. Rejects noise ripple and shallow dips that do not represent real carrier separation.

Why 50th percentile (not mean)?

Mean is sensitive to outliers at valley edges. Median is robust — gives stable estimate even if a few valley-edge samples are slightly elevated.

GNT Usage in System

CASC threshold: $\text{gnt} + 1.2$ dB

Edge walk stop: $\text{gnt} + 1.5$ dB

`use_gnt` gate: `local_min` within 40% of carrier C/N

Correlation filter: $\text{gnt} + 3.0$ dB for interference tracks

Global Noise Threshold (GNT) (contd..)

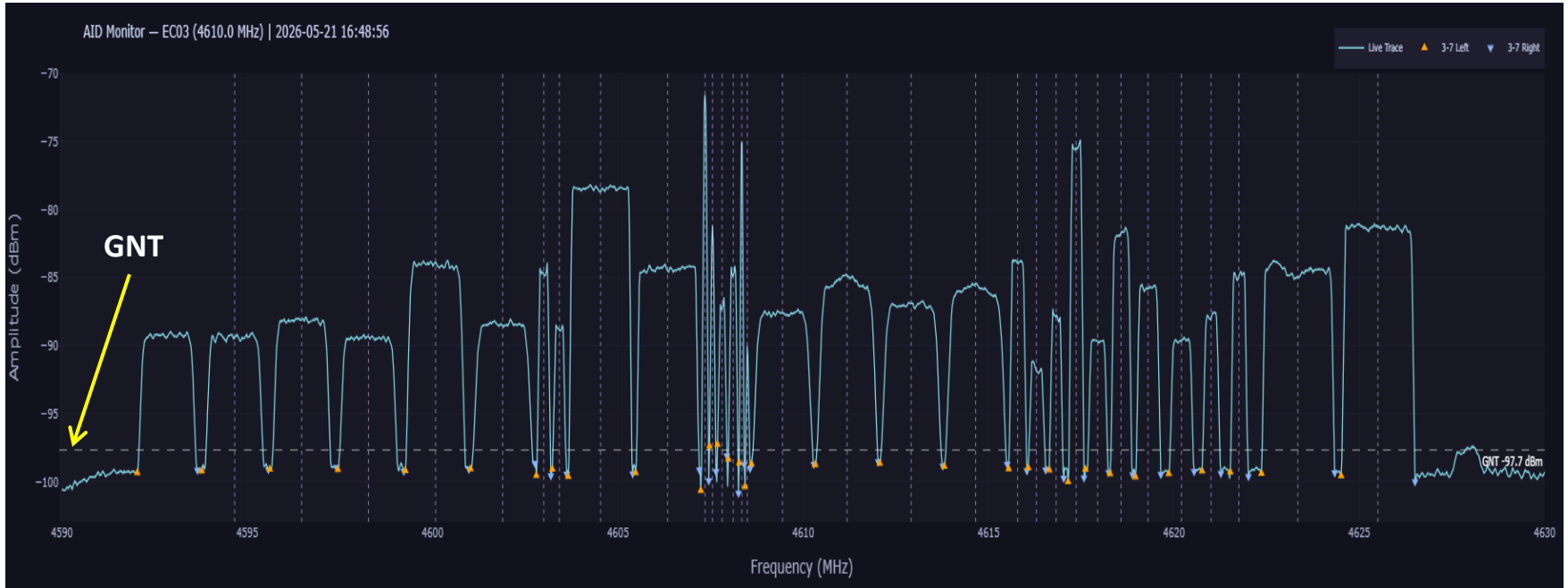

Carrier Aware Spectral Cursor (CASC)

What CASC Does

Scans all inter-carrier gaps — spectral regions between known carriers — for unauthorized signals or energy levels rising above the noise floor. Any energy found here is not a legitimate carrier and must be flagged.

1

Build Exclusion Zones

For every active carrier, the region $ba_l \rightarrow ba_r$ is excluded. CASC only scans spectral bins outside all carrier footprints.

2

Detect Noise Rise

Scan remaining bins. If $y_s[idx] > gnt + 1.2$ dB, mark as noise rise start. Walk forward until amplitude drops back to $\leq gnt$. That run = one CASC hit.

3

Threshold Filtering

Peak of hit must exceed $gnt + 3.0$ dB to be forwarded to the Interference Correlation Engine. Weaker hits are still logged but not correlated.

4

Interference Correlation

Qualifying hits are tracked over time. CASC feeds the correlation engine which matches signal amplitude patterns against known carriers using Pearson + peak cross-correlation.

Carrier Aware Spectral Cursor (CASC)(contd..)

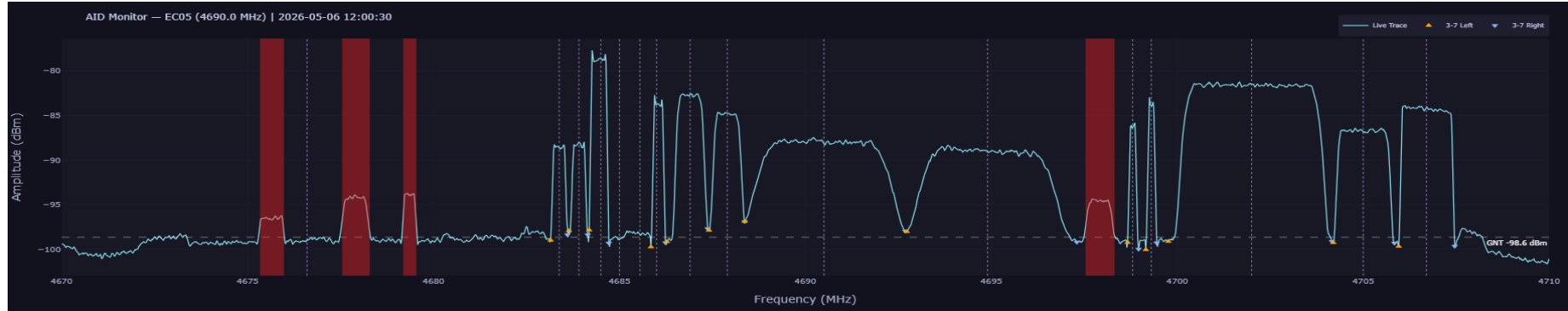

Carrier Anomaly Detector (CAD)

Centroid Detection

Formula

$c_f = \Sigma(f \times P) / \Sigma P$ where $P = 10^{(y/10)}$ Flag if $|c_f - fc_mhz| > 0.03 \times bw_hz$

What it catches

Asymmetric interference — any signal that pulls the power-weighted center frequency away from the known chart frequency.

Why linear power (not dB)?

Centroid in dB underweights high-amplitude regions. Linear power correctly weights dominant spectral components — the carrier peak matters most.

Why 3% of bandwidth?

At 2 MHz carrier → threshold = 60 kHz. Tight enough to catch real shift, wide enough to tolerate natural filter asymmetry and sweep-to-sweep variation.

No early return

Centroid originally returned early after detection, blocking hump and spike. Removed — all three detectors now run in parallel so multiple anomaly types can be flagged simultaneously.

📌 Blind Spots

Symmetric interference (equal power both halves) → centroid does not shift.
Skirt-region interference at low power → drowned out by flat-top in linear weighting.

Centroid Detection (contd..)

Centroid Detection Diagram

Case 1: Clean Carrier
(No interference)

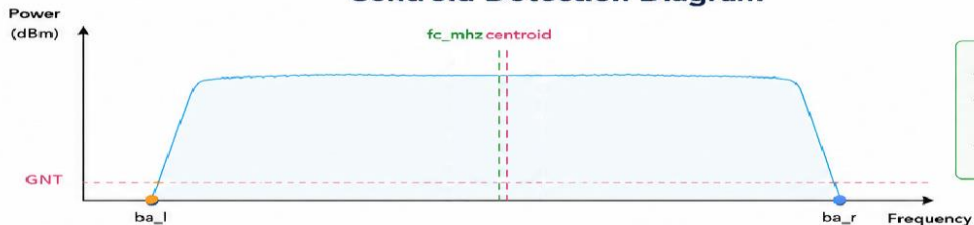

- Clean carrier with no interference.
- Centroid is very close to the known carrier center (f_{c_mhz}).
- Weight is balanced.

Case 2: Hump on Left Side
(Interference on left)

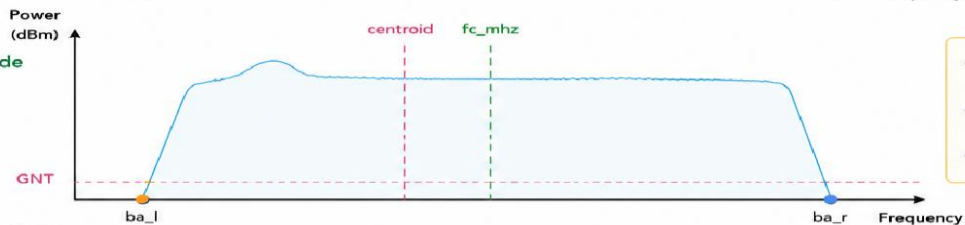

- Interference (hump) on the left side of the carrier.
- More power on the left pulls the centroid to the left.
- Centroid shifts left of f_{c_mhz} .

Case 3: Hump on Right Side
(Interference on right)

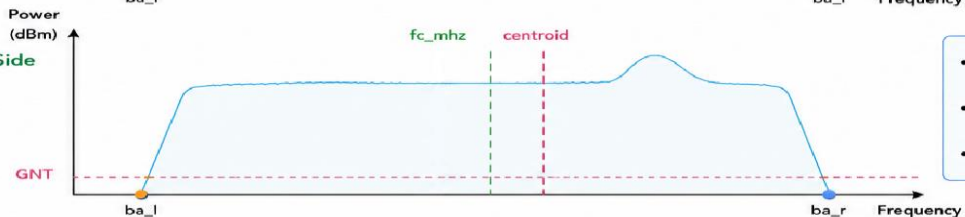

- Interference (hump) on the right side of the carrier.
- More power on the right pulls the centroid to the right.
- Centroid shifts right of f_{c_mhz} .



Hump Detection + *ShoulderExcess* Fallback

Method — `check_for_interfering_hump()`

1. Apply 15% margin from both edges → focus on core only. 2. `roof_h` = 30th percentile of core. 3. Flag regions where amplitude – `roof_h` > 1.2 dB AND run width > 8% of carrier AND ≥ 3 pts.

Why 30th percentile?

For a clean flat-top, 30th pct \approx carrier floor. A hump pushes points above it. Robust to small ripple since it reacts only when a significant fraction of points are elevated.

Why 1.2 dB threshold?

Carrier passband ripple is typically <0.5 dB for clean signals. 1.2 dB gives sufficient margin above normal ripple without requiring large interference power.

Why 8% min width?

Rejects narrow spikes accidentally passing amplitude threshold. A genuine hump from an interfering carrier has spectral width proportional to its symbol rate — it cannot be arbitrarily narrow.

Why 15% margin exclusion?

Carrier edges have natural rolloff that could be mistaken for humps. Excluding 15% each side removes this ambiguity entirely — only interior bumps are scanned.

ShoulderExcess Fallback

If hump scan finds nothing: check full `ba_l`→`ba_r` for regions where $y > \max(y[\text{sh}_l], y[\text{sh}_r]) + 2.7$ dB.
Catches symmetric humps placed exactly at the shoulders — inside the 15% exclusion zone of normal hump detection.

Hump Detection + *ShoulderExcess* Fallback

HUMP DETECTION – TECHNIQUE EXPLAINED

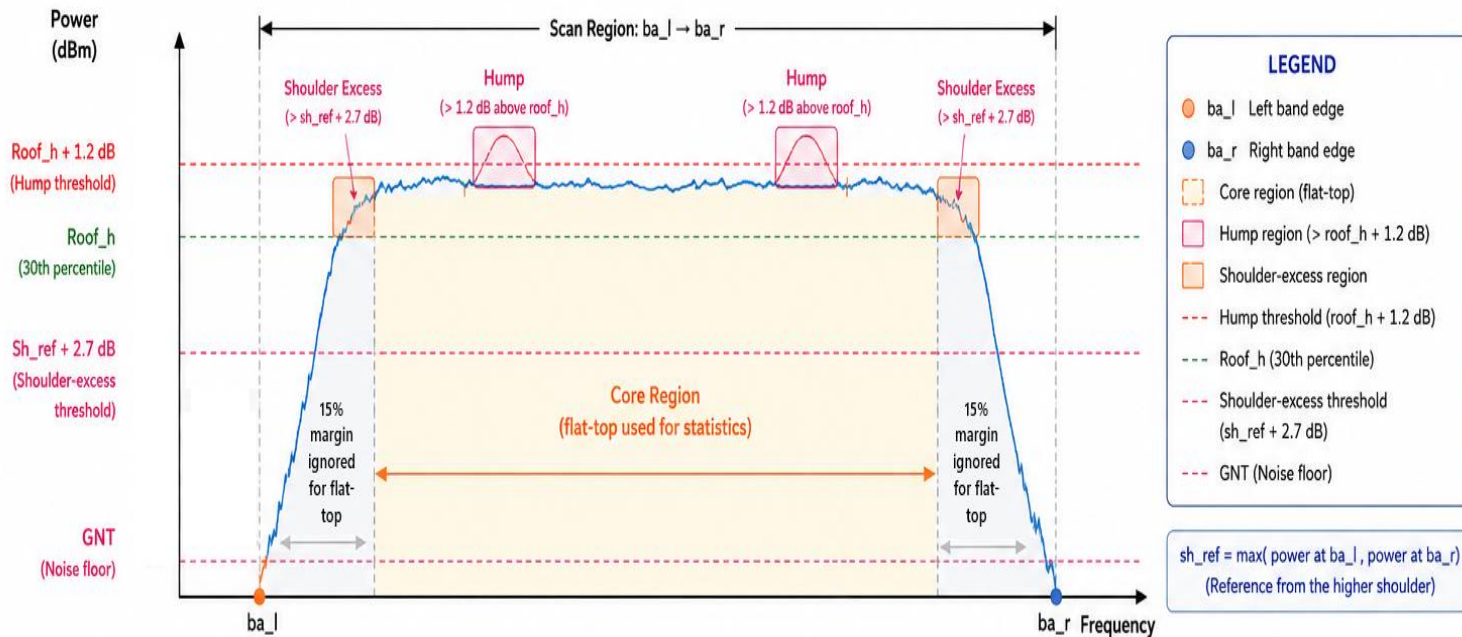

Hump Detection + *ShoulderExcess* Fallback

CASE A — HUMP DETECTION (Big humps above $\text{roof}_h + 1.2$ dB)

- 1 Select scan region from ba_l to ba_r .
- 2 Exclude 15% margin on both sides to get the flat-top (core) region.
- 3 Compute $\text{roof}_h = 30$ th percentile of power within the core region.
- 4 Threshold = $\text{roof}_h + 1.2$ dB.
- 5 Find contiguous regions inside the scan region where power > ($\text{roof}_h + 1.2$ dB).
If width > 8% of total scan width and at least 3 points → Flag as HUMP.

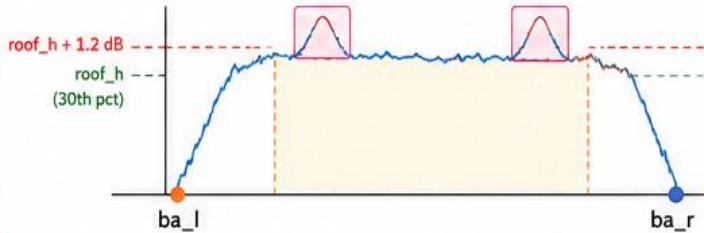

Result

Hump regions returned with (start_index, end_index).

CASE B — SHOULDER EXCESS FALLBACK (Humps as “ears”)

- 1 Compute $\text{sh_ref} = \max(\text{power at } \text{ba}_l, \text{power at } \text{ba}_r)$.
- 2 Threshold = $\text{sh_ref} + 2.7$ dB.
- 3 Find contiguous regions anywhere in the scan region ($\text{ba}_l \rightarrow \text{ba}_r$) where power > ($\text{sh_ref} + 2.7$ dB).
- 4 No restriction relative to carrier center — can occur on either side.
- 5 Return those regions as ShoulderExcess (fallback when no hump found).

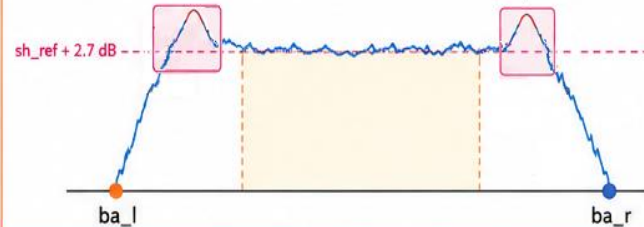

Result

Shoulder-excess regions returned with (start_index, end_index).

Special scenario: Hump at center of carrier

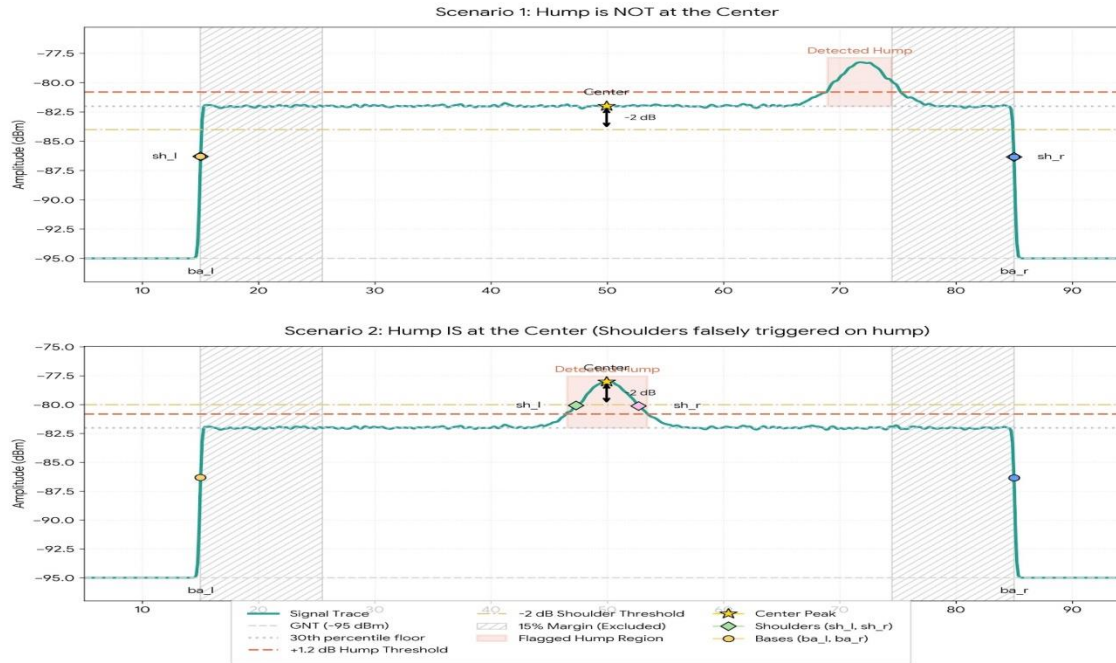

Center Hump Special Case:

TransitionStep is independent — triggers whenever t_candidates exist, regardless of Centroid, Hump or Spike. Corrected shoulders (sh_l_corr / sh_r_corr) are a sub-feature within TransitionStep — computed (via 30th percentile - 2.0 dB) only when hump_found is additionally True, to correctly gate candidates falling in the true skirt vs hump-inflated shoulder region. All other detection uses original sh_l / sh_r. If no center hump → original sh_l / sh_r are used.

Spike Detection

Wide Carrier (bw \geq 350 kHz)

Scan range:	ba_l \rightarrow ba_r (full carrier including skirts)
Baseline:	roof_s = 50th percentile of core
Threshold:	amplitude – roof_s $>$ 3.0 dB
Base expansion:	Expand group while core[i] $>$ roof_s + 0.3 dB
Multi-spike:	Each spike gets own box
Dedup:	Skips regions already flagged by Hump/ShoulderExcess (Centroid excluded from dedup to avoid suppressing spikes)

Narrow Carrier (bw $<$ 350 kHz)

Scan range:	sh_l \rightarrow sh_r (shoulder-to-shoulder only)
Baseline:	med = median of core
Threshold:	amplitude – med $>$ 2.5 dB
Base expansion:	Expand group while core[i] $>$ med + 0.3 dB
Multi-spike:	Each spike gets own box
Why 2.5 (not 3.0)?:	Narrow core \rightarrow median more stable \rightarrow lower threshold safe without extra false positives

Spike Detection

SPIKE DETECTION

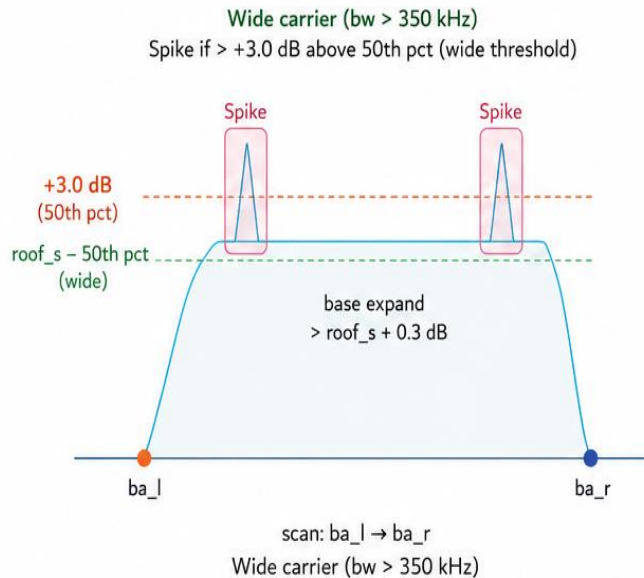

Narrow carrier (bw < 350 kHz)
Spike if > +2.5 dB above median (narrow threshold)

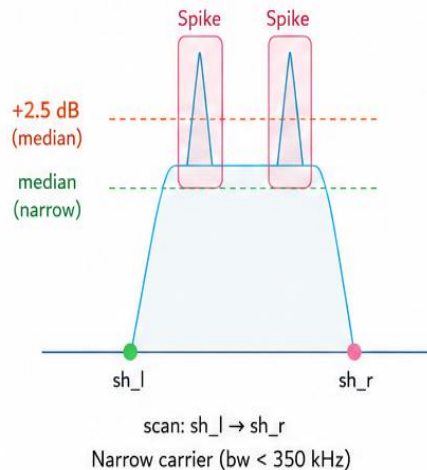

Key thresholds

- roof_s - 50th pct (wide)
- median (narrow)
- +3.0 dB (wide)
- +2.5 dB (narrow)
- sh_ref + 2.7 dB (skip center)
- Spike / Hump box

TransitionStep Detection — Skirt Plateau Anomaly

What it catches:

A step-like plateau in the carrier transition/skirt region. A clean carrier rolls off monotonically. A plateau indicates interference causing the edge to stall mid-rolloff.

1

Collect $t_candidates$

During the 3-7 walk, every point where the 3-7 condition fired but the GNT gate prevented stopping is stored as a candidate.

2

Flatness check (0.9 dB)

For each candidate, check a 10-point window: if $\max - \min < 0.9$ dB \rightarrow plateau confirmed. Normal rolloff shows >1 dB variation across any 10 points.

3

Drop confirmation (2.0 dB)

Beyond the plateau, verify a real descent to noise: $\text{amp} - \min(\text{drop_zone}) > 2.0$ dB. Ensures plateau precedes genuine edge, not just mid-slope noise.

4

Flag skirt region

ExactIndices = $ba_l \rightarrow sh_l_corr$ (left) or $sh_r_corr \rightarrow ba_r$ (right). Boxes the entire anomalous skirt section.

TransitionStep Detection — Skirt Plateau Anomaly

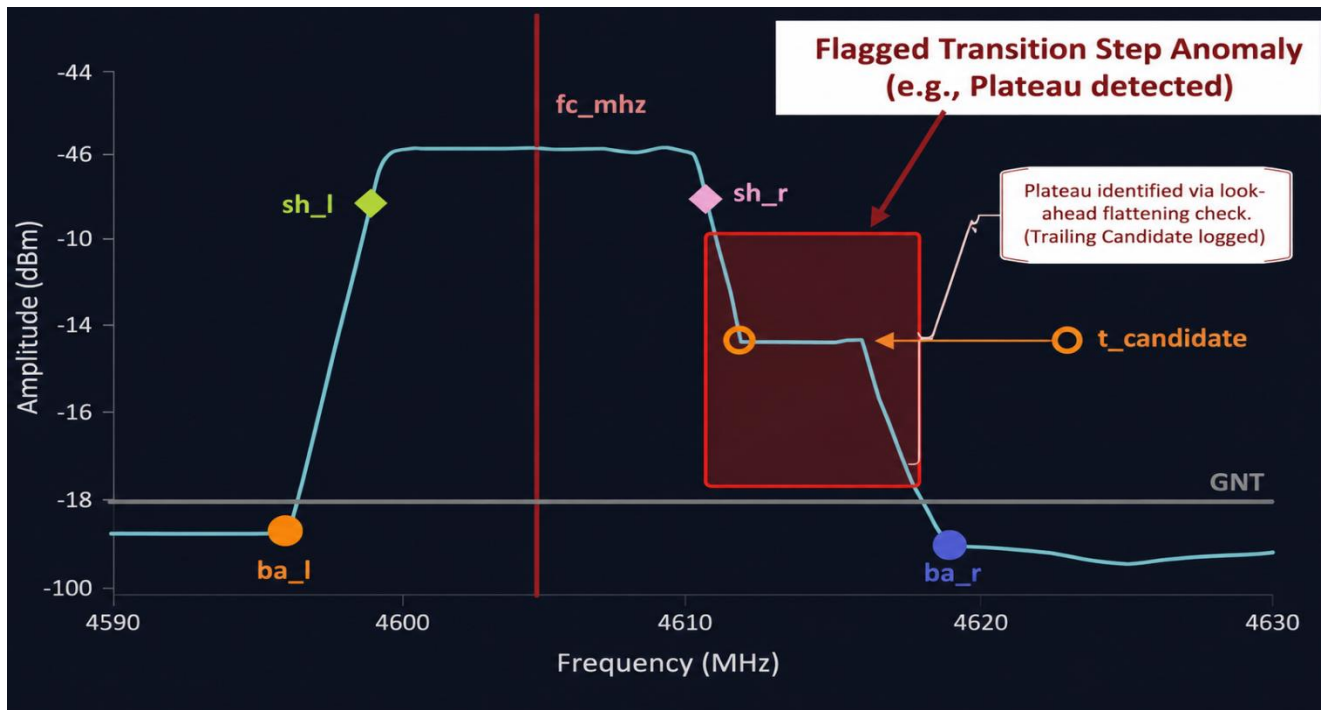

Interference Detection Test Setup

RF injection at known transmission frequencies using Satellite Modems

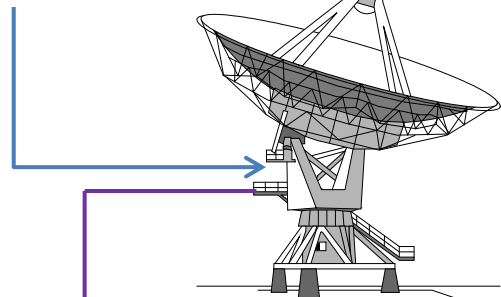

SATCOM control center

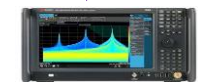

Interference detection system

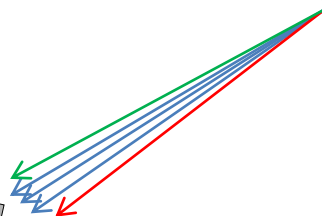

Station-n



Station-2



Station-1

Results

CASC Detection of 3 Unauthorised Transmissions

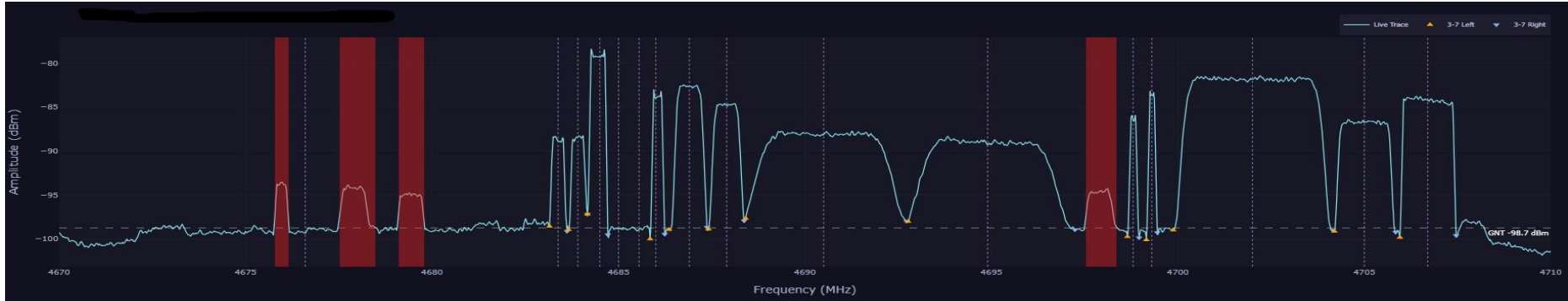

Combined Detection of CASC and CAD (Hump detection)

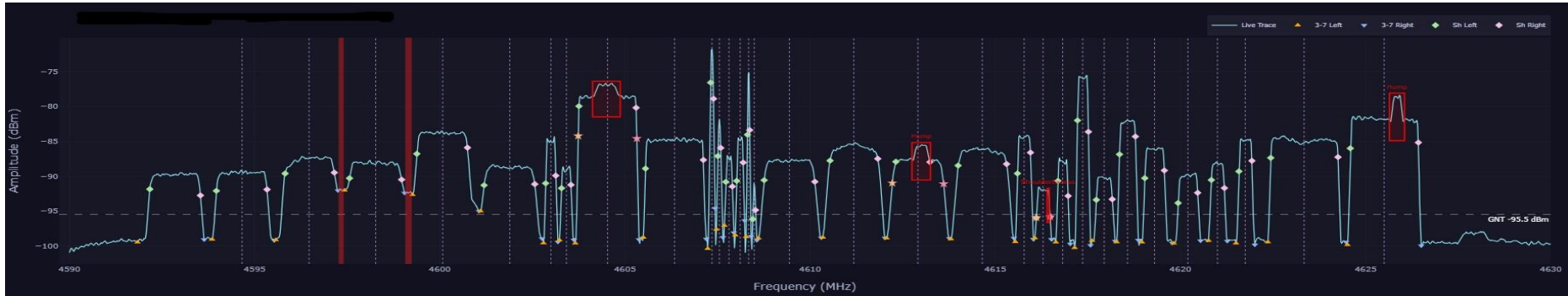

Results

CASC + Centroid, Hump and Spike detection

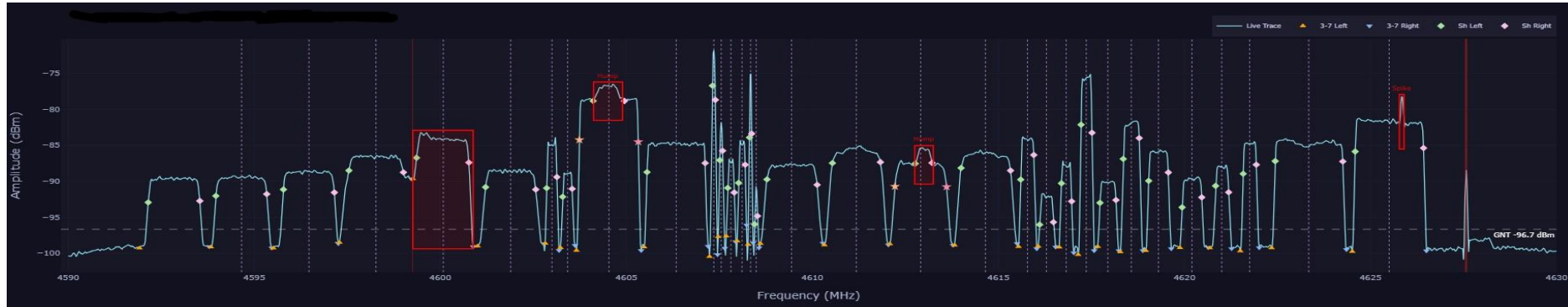

Spike detection across multiple carriers

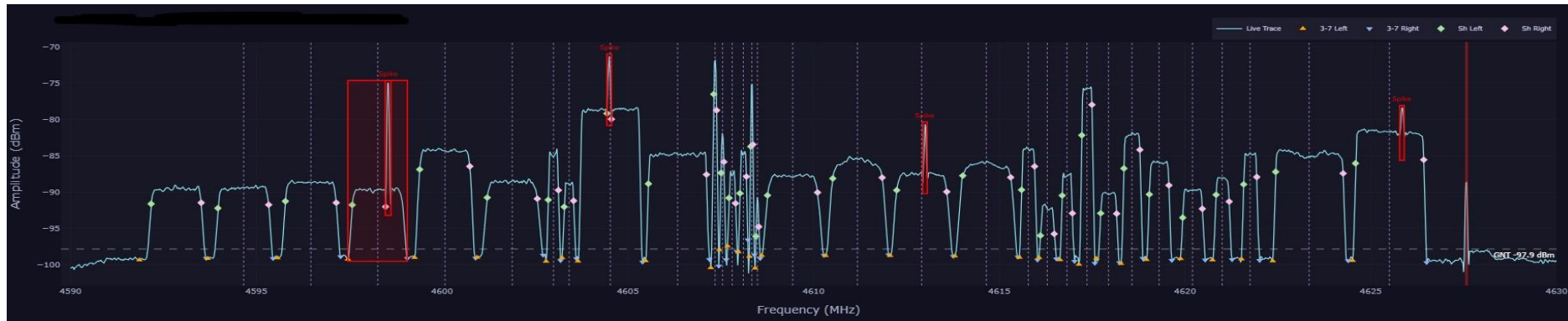

Results

Centroid triggered when Hump and Spike is on the same side of the carrier



Hump and Spike on either side of the carrier

Results

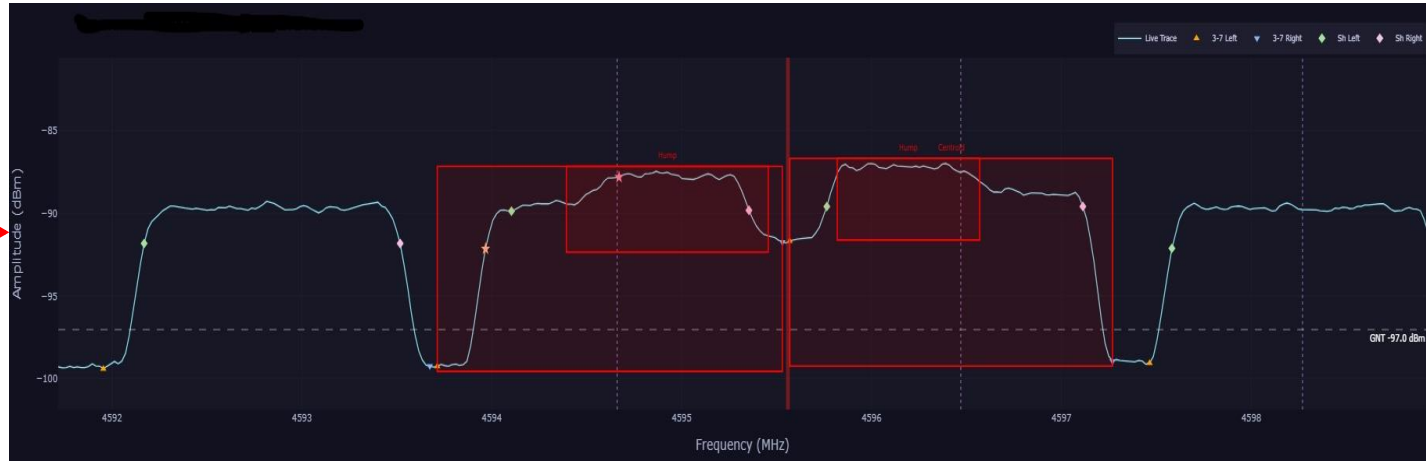
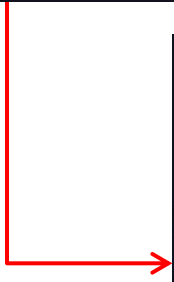
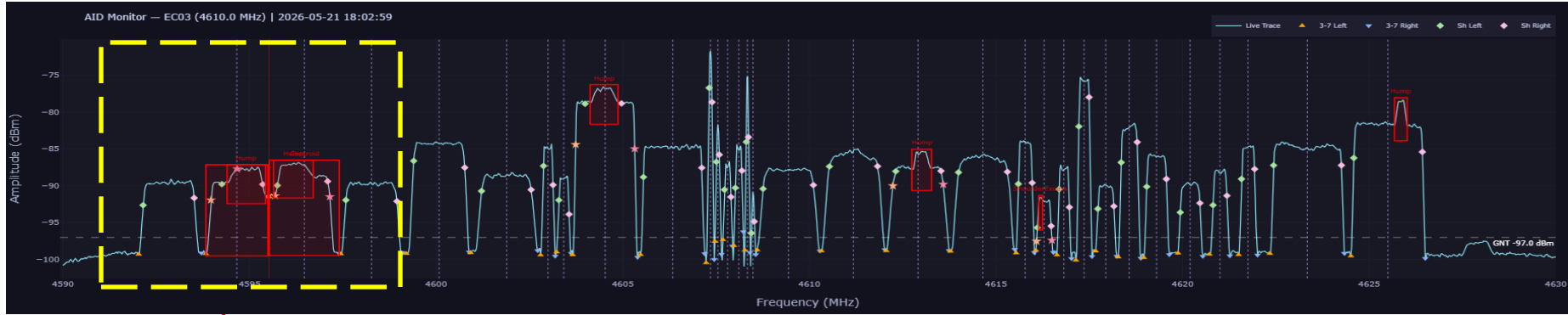

The region inside the yellow box is zoomed to see the flagging

Results

CASC, Hump and Spike detection in different transponder

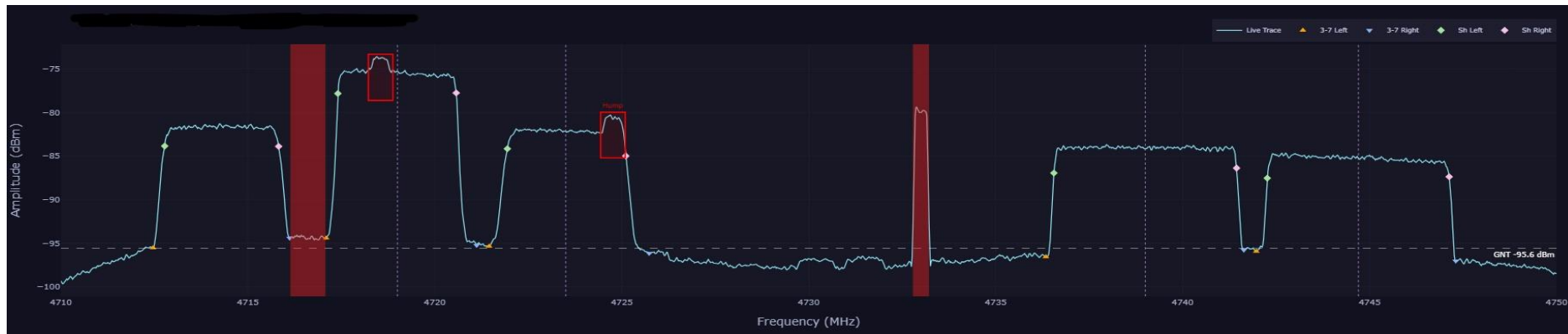
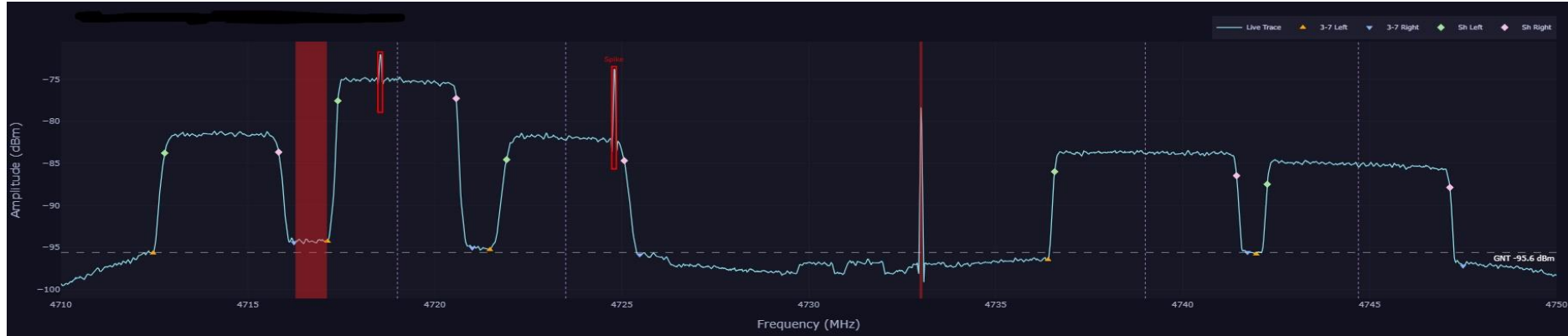

Results

Transponder spectrum with Multiple Detection Scenarios

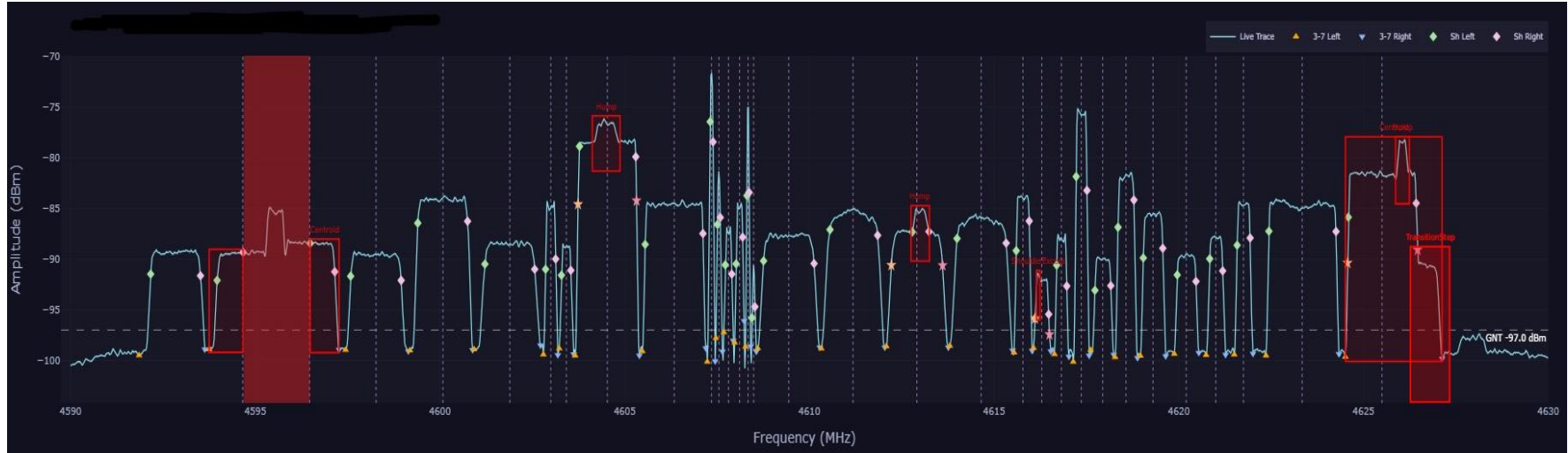

Conclusions

- ❑ Various interferences affecting satellite communication networks were discussed
- ❑ Interference appear as anomaly in the downlink spectrum monitored
- ❑ For FDMA systems, dedicated bandwidth is allotted for each carriers making the interference detection in these systems very crucial
- ❑ An automatic interference detection using dual domain structural method is discussed
- ❑ In the proposed method, noise domain and carrier domains are evaluated separately
- ❑ An edge detection method was developed called the *3-7 system* for identifying the left and right points of carrier where it merges into the noise floor
- ❑ Global noise threshold (GNT) is estimated using valley median method
- ❑ Together with GNT and left-right points of each carriers identified, noise and carrier regions in a spectrum are identified
- ❑ *Carrier Aware Spectral Cursor (CASC)* operates on the noise region whereas *Carrier Anomaly Detector (CAD)* operates on the carrier region
- ❑ Unauthorized transmissions and power rises in the noise region is captured by CASC whereas CAD detects various type of anomalies such as hump, spike, shoulder excess and transition-step anomalies.
- ❑ Using CASC and CAD together, both noise and carrier region anomalies are detected
- ❑ The interference detection system was deployed in ISTRAC satellite communication network and tested extensively using varying types of interferences injected manually into the spectrum

THANK YOU!